

# AFINOX

## Cycles:



**Blast Chilling**

**9kg**

+90°C / +3°C  
(90mins)



**Blast Freezing**

**7kg**

+90°C / -18°C  
(240mins)



**Thawing**



**Preservation**

## Capacity:

Useful Internal Dimensions: 545x350x240mm

Trays GN 3 of GN1/1 (Height 40mm)

5L Pans 2 of 5L Pans (165x360xH120 mm)

## Specifications:

Dimensions:	(WxDxH)	650x600x50mm
Net Weight:	kg	62kg
Refrigerant Gas:		R404A
Refrigeration Power:	W	1,416 (-10°C / +40°C) 586 (-30°C / +40°C)
Electronic Card:		Touch PLD Control Panel
Compressor:		EMBRACO NEU2178GK (Hermetic)
Voltage & Frequency:	V / Hz	230 / 1Ph / 50
Max Current Draw:	A	7.26
Absorbed Power:	W	510 (-30°C / +40°C)
Noise:	DB	50 (5m)
Climate Class:		5 (40°C - 40% RH)

## Features:



Simple User-Friendly PLD Touch Control Panel



Made from Environmentally Friendly Materials & Methods

Basic HACCP Reporting

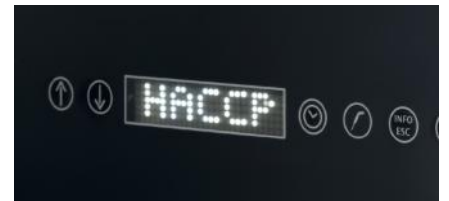

Heavy Duty Food Core Probe



Run Automatic or Manual Cycles  
by Time or Temperature

**ABLE**

**Phone:**  
08 9242 7521  
**Head Office:**  
8 Guthrie Street,  
Osborne Park WA 6017

**Email:**  
sales@ableproducts.com.au  
**Web:**  
www.ableproducts.com.au

## FASTER 3

Product Code:

9AMF03IM5SA01



# FASTER

## Optional Accessories:



Foot Kit



LED Lighting

Drawings:

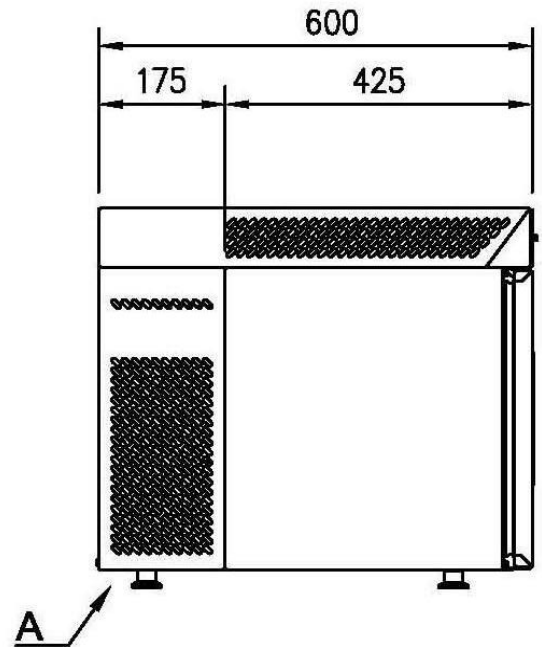
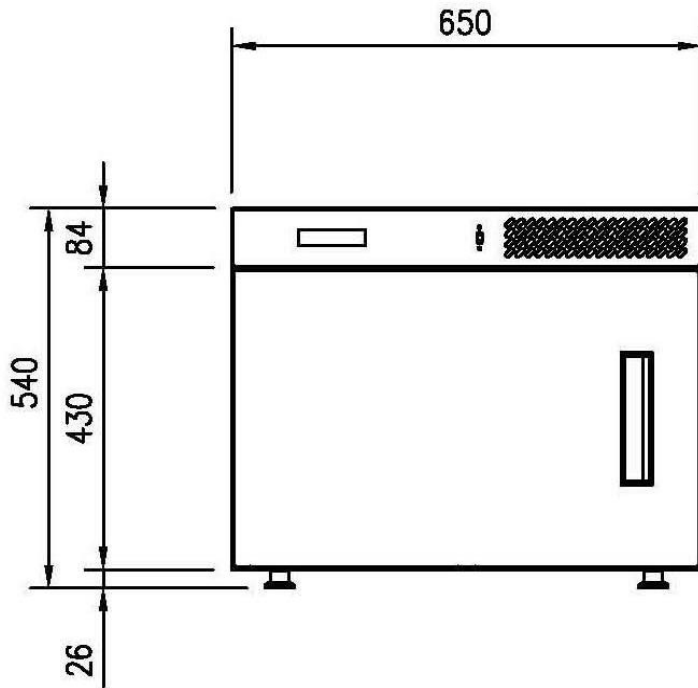

Standard Version:

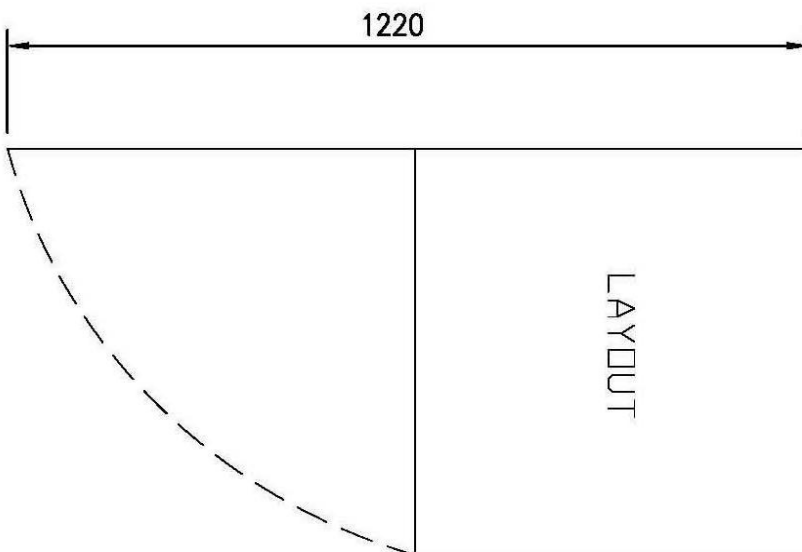

A= ELECTRICAL CONNECTION  
D= WATER DISCHARGE  $\varnothing 18$  (F)

**ABLE**

**Phone:**  
08 9242 7521  
**Head Office:**  
8 Guthrie Street,  
Osborne Park WA 6017

**Email:**  
sales@ableproducts.com.au  
**Web:**  
www.ableproducts.com.au